

High Power LED
3535

351J White Series
RA70

For Outdoor Lighting

Features & Benefits

- Package : 3pad design with Al2O3
- Dimension : 3.50 mm X 3.50 mm
- Maximum current : 0.7 A

DESIGN

Table of Contents

1.	Characteristics	-----	3
2.	Product Code Information	-----	4
3.	Typical Characteristics Graphs	-----	8
4.	Outline Drawing & Dimension	-----	10
5.	Reliability Test Items & Conditions	-----	11
6.	Soldering Conditions	-----	12
7.	Tape & Reel	-----	13
8.	Label Structure	-----	15
9.	Packing Structure	-----	16
10.	Precautions in Handling & Use	-----	18

1. Characteristics

a) Absolute Maximum Rating

Item	Symbol	Rating	Unit	Condition
Ambient / Operating Temperature	T_a	-40 ~ +105	°C	-
Storage Temperature	T_{stg}	-40 ~ +105	°C	-
LED Junction Temperature	T_j	125	°C	-
Forward Current	I_f	700	mA	-
Pulse Forward Current	I_{fp}	1500	mA	Duty 1/10, pulse width 10ms
Assembly Process Temperature	-	260 <10	°C s	-
ESD (HBM)	-	2	kV	-

b) Electro-optical Characteristics ($I_f = 700 \text{ mA}$, $T_s = 25 \text{ °C}$)

Item	Unit	Rank	Min.	Typ.	Max.
Forward Voltage (V_f)	V	V0	2.8	-	3.2
Color Temperature(CCT)	K		6000	-	6500
Color Rendering Index (R_a)	-		70	-	-
Luminous Flux (Φ_v)	lm		300	-	400
Thermal Resistance (junction to solder point)	°C/W		-	3.5	-
Beam Angle	°		-	120	-

Note:

Ledstar maintains measurement tolerance of: Radiant Power = $\pm 7 \%$, forward voltage = $\pm 0.1 \text{ V}$, Wavelength = $\pm 2 \text{ nm}$

2. Product Code Information

1	2	3	4	5	6	7	8	9	10	11	12	13	14	15	16	17	18	19	20	21		
L	D	R	-	3	5	3	5	C	L	F	6	3	7	0	-	V	0	A	6	3	E	0

Digit	PKG Information	Code	Specification										
1 2 3	Ledstar Package Middle Power	LDR											
4 5 6 7	Package Model and Size	3535	3.5 x 3.5 x 2.48mm										
8	Product Category	C	Ceramics										
9	Bracket Type	L	Al2O3										
10	Version	F											
11 12	Nominal CCT	63	6000-6500K										
13 14	RA	70	Min. 70										
15 16	Forward Voltage (V)	V0	<table border="0"> <tr> <td>2.8-3.2</td> <td>Bin Code:</td> <td>F0 2.8-3.0</td> <td>F1 2.8-2.9</td> <td>F2 2.9-3.0</td> </tr> <tr> <td></td> <td></td> <td>G0 3.0-3.2</td> <td>G1 3.0-3.1</td> <td>G2 3.1-3.2</td> </tr> </table>	2.8-3.2	Bin Code:	F0 2.8-3.0	F1 2.8-2.9	F2 2.9-3.0			G0 3.0-3.2	G1 3.0-3.1	G2 3.1-3.2
2.8-3.2	Bin Code:	F0 2.8-3.0	F1 2.8-2.9	F2 2.9-3.0									
		G0 3.0-3.2	G1 3.0-3.1	G2 3.1-3.2									
17 18 19	Chromaticity Code	A63	6000-6500K										
20 21	Luminous Flux Efficiency (lm/w)	E0 FB EA	FB EA 165-175 170-180										

a) Luminous Flux Bins ($I_F = 700 \text{ mA}$, $T_s = 25^\circ\text{C}$)

RA Min.	Nominal CCT (K)	Product Code	Flux Rank	Flux Bin	Flux Range (Φ_v , lm)	Flux Efficiency Range (lm/w)
70	6300	LDR-3535CLF6370-V0A63E0	E0	FB	300-400	165-175
				EA	300-400	170-180

b) Color Bins ($I_F = 700 \text{ mA}$, $T_s = 25^\circ\text{C}$)

RA Min.	Nominal CCT (K)	Product Code	CCT Range (K)	Color Rank	Chromaticity Bin
70	6300	LDR-3535CLF6370-V0A63E0	6000-6500	SDCM<6 Bin	A63

c) Voltage Bins ($I_F = 700 \text{ mA}$, $T_s = 25^\circ\text{C}$)

RA Min.	Nominal CCT (K)	Product Code	Voltage Rank	Voltage Bin	Voltage Range (V)
70	6300	LDR-3535CLF6370-V0A63E0	V0	F1	2.8 - 2.9
				F0	
				F2	2.9 - 3.0
				G0	
				G1	3.0 - 3.1
				G2	3.1 - 3.2

d) Chromaticity Region & Coordinates ($I_f = 700 \text{ mA}$, $T_s = 25^\circ\text{C}$)

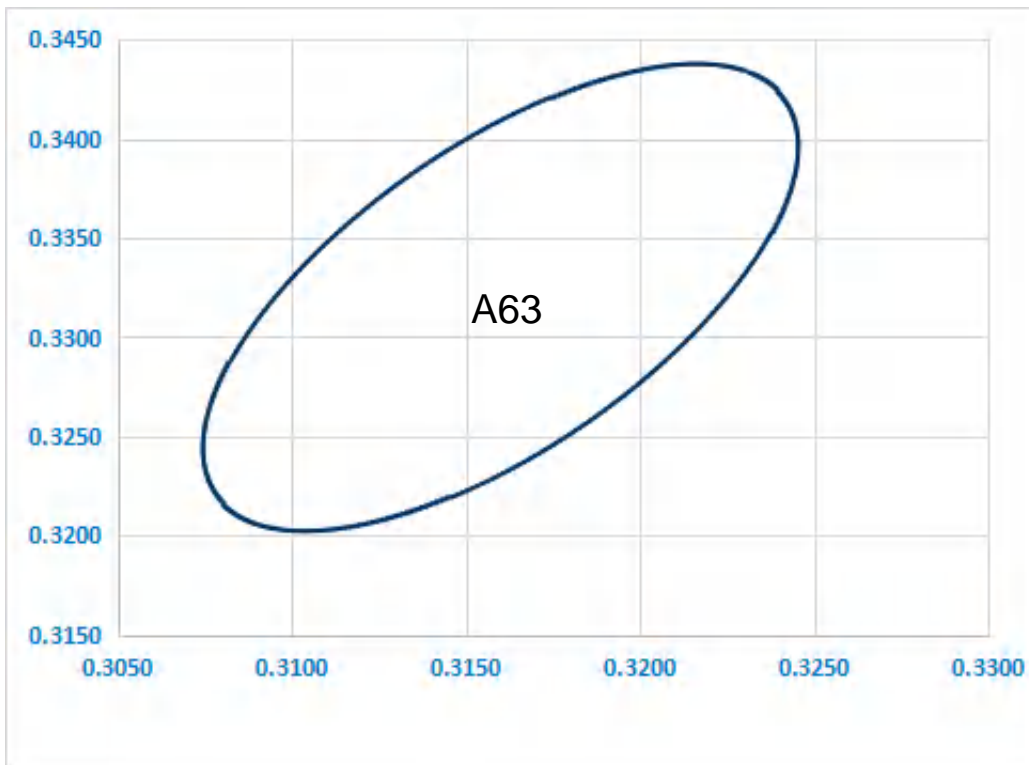

e) Chromaticity Region & Coordinates ($I_f = 700 \text{ mA}$, $T_s = 25^\circ\text{C}$)

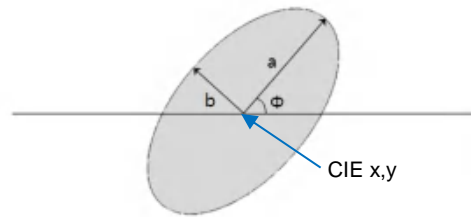

CCT	CIE-X	CIE-Y	θ	a	b	BIN
6000-6500K	0.3160	0.3320	58.23	0.00223	0.00095	A63

Note:

Ledstar maintains measurement tolerance of: $C_x, C_y = \pm 0.005$

3. Typical Characteristics Graphs

a) Spectrum Distribution ($I_F = 700 \text{ mA}$, $T_s = 25^\circ\text{C}$)

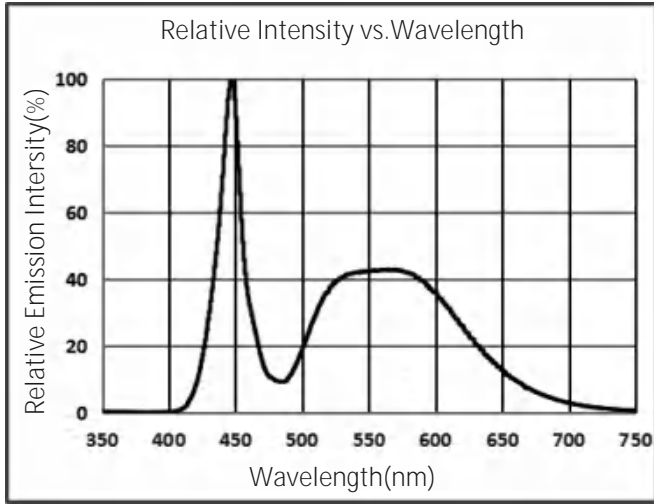

b) Temperature Characteristics ($I_F = 700 \text{ mA}$)

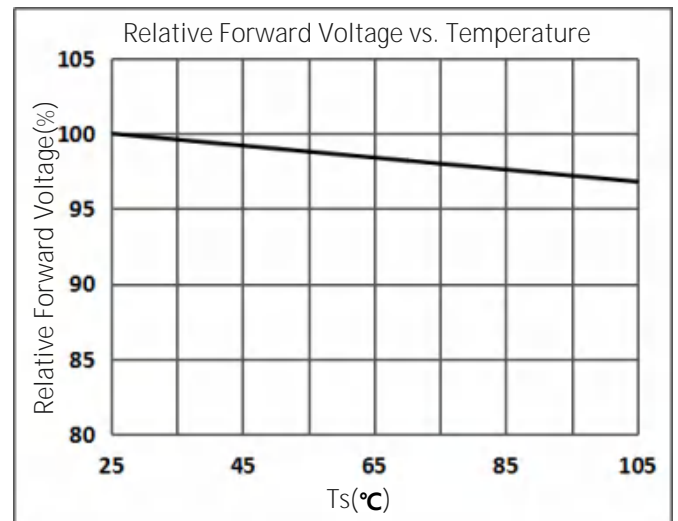
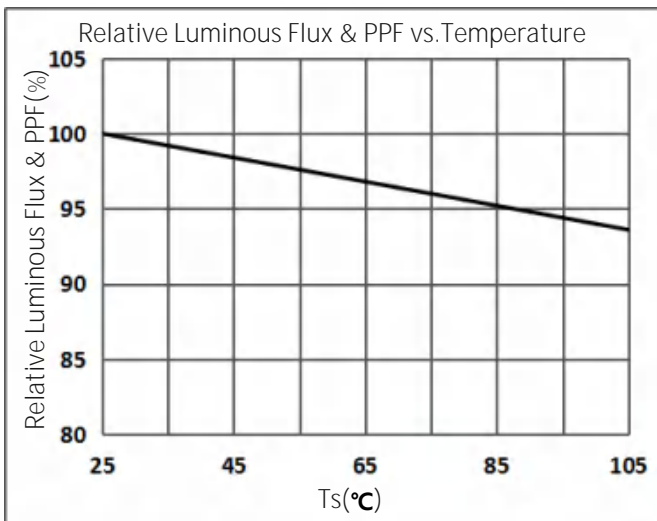

c) Forward Current Characteristics ($T_s = 25^\circ\text{C}$)

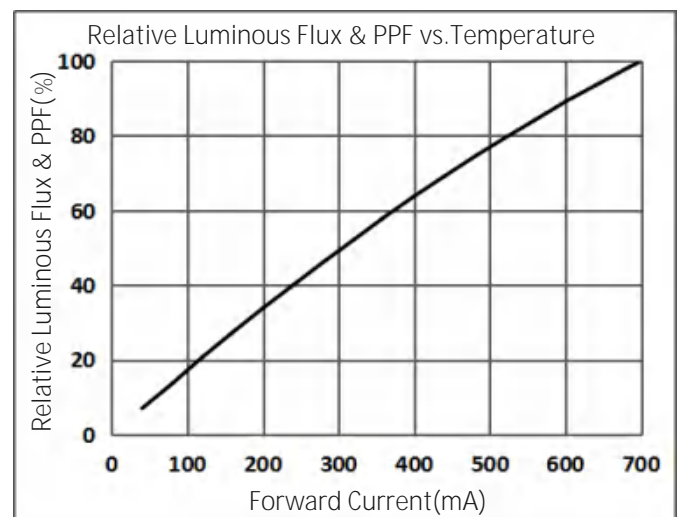
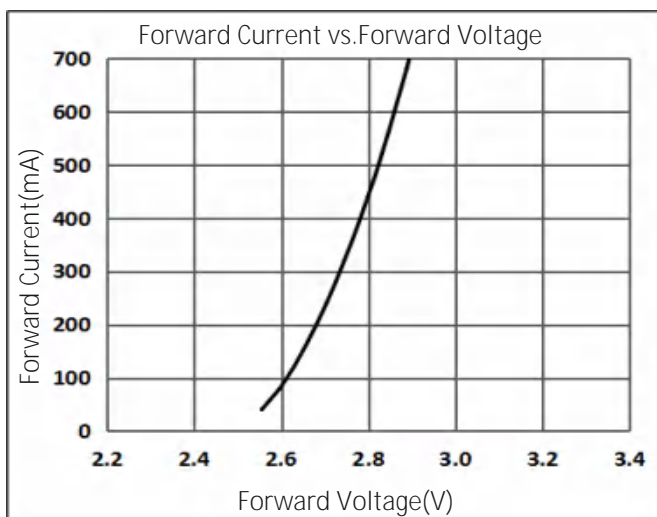

d) Color Shift Characteristics, $T_s = 25^\circ\text{C}$

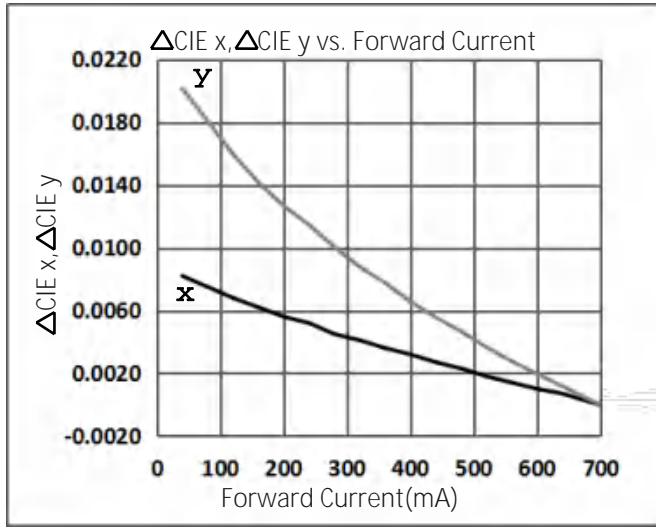

e) Derating Curve

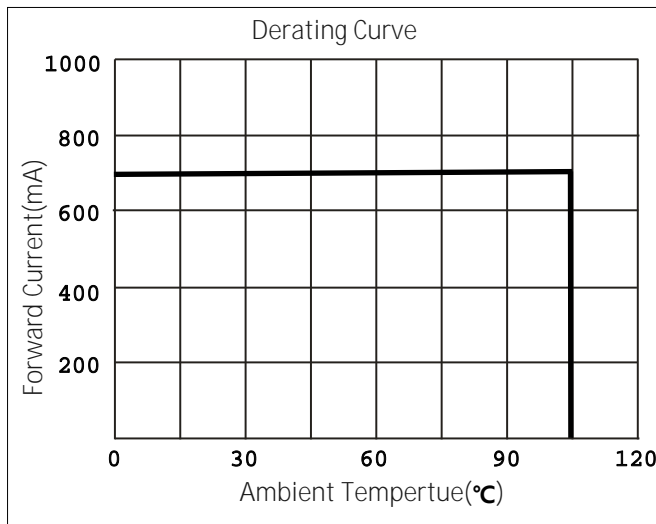

f) Beam Angle Characteristics ($T_s = 25^\circ\text{C}$, $I_f = 700 \text{ mA}$)

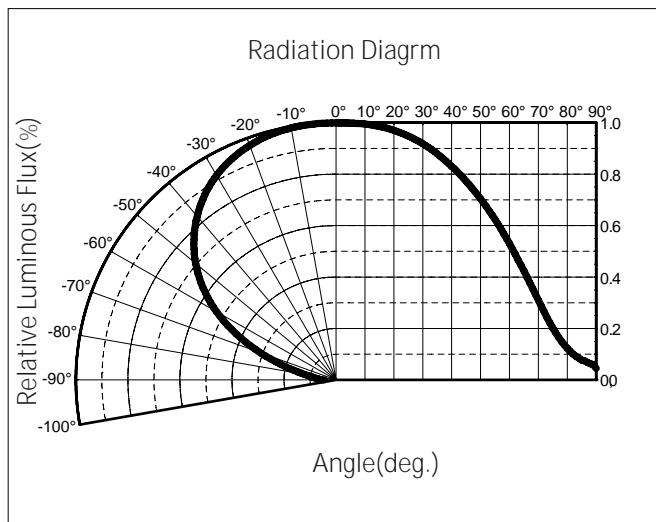

4. Outline Drawing & Dimension

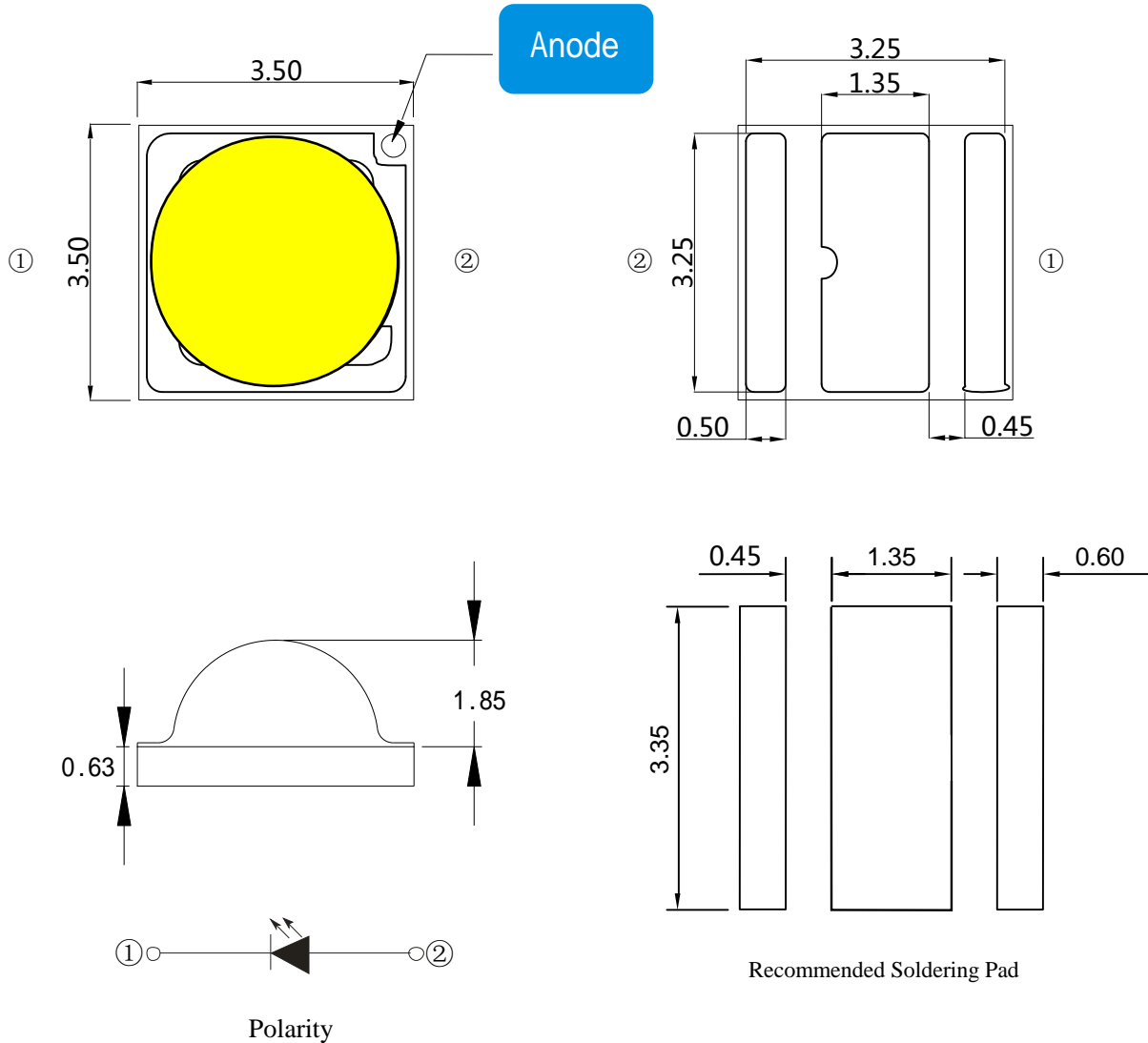

Notes:

T_s point and measurement method:

- ① Measure one point at the cathode pad, if necessary remove PSR of PCB to reach T_s point.
- ② All pads must be soldered to the PCB to dissipate heat properly, otherwise the LED can be damaged.
- ③ All dimensions in mm. Tolerances unless mentioned is ± 0.1 mm.

Precautions:

- 1) Pressure on the LEDs will influence to the reliability of the LEDs. Precautions should be taken to avoid strong pressure on the LEDs. Do not put stress on the LEDs during heating.
- 2) Re-soldering should not be done after the LEDs have been soldered. If re-soldering is unavoidable, LED's characteristics should be carefully checked before and after such repair.
- 3) Do not stack assembled PCBs together. Since materials of LEDs is soft, abrasion between two PCB assembled with LED might cause catastrophic failure of the LEDs.

5. Reliability Test Items & Conditions

a) Test Items

Test Item	Test Condition	Test Hour / Cycle	Sample No.
Room Temperature Life Test	25°C, DC 700 mA	1000 h	22
High Temperature Life Test	85°C, DC 700 mA	1000 h	22
High Temperature Humidity Life Test	85°C, 85 % RH, DC 700 mA	1000 h	22
Low Temperature Life Test	-40°C, DC 700 mA	1000 h	22
Powered Temperature Cycle Test	-40 °C ~ 85°C, each 10 min, On/Off 5min , Temp. Change Time 20min, DC 700 mA	100 cycles	22
Thermal Cycle	-40°C / 15 min ↔ 105°C / 15 min → Hot plate 180°C	100 cycles	100
High Temperature Storage	105°C	1000 h	22
Low Temperature Storage	-40°C	1000 h	22

b) Criteria for Judging the Damage

Item	Symbol	Test Condition (Ts = 25°C)	Limit	
			Min	Max
Forward Voltage	V _F	I _F = 700 mA	Init. Value * 0.9	Init. Value * 1.1
Luminous Flux	Φ _v	I _F = 700 mA	Init. Value * 0.7	Init. Value * 1.1

6. Soldering Conditions

a) Reflow Conditions (Pb free)

Reflow frequency: 2 times max.

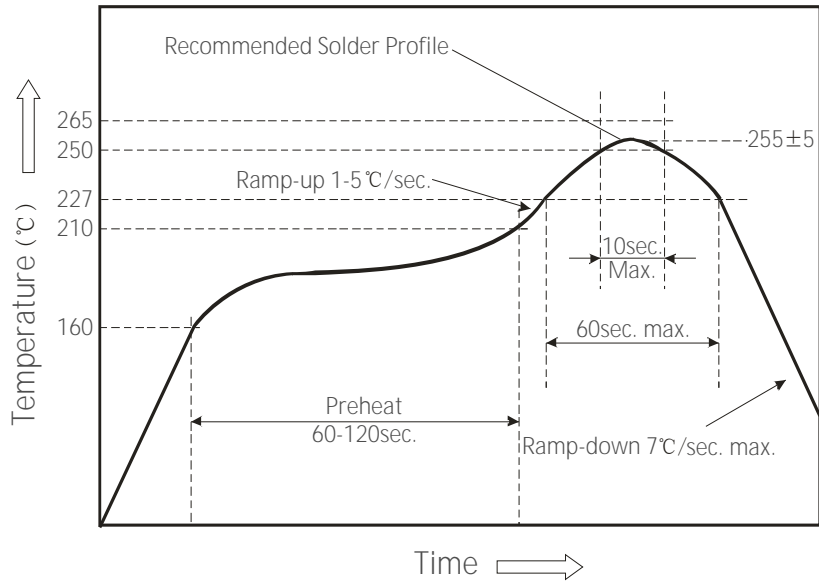

b) Manual Soldering Conditions

Not more than 5 seconds @ max. 300°C, under soldering iron.

7. Tape & Reel

a) Taping Dimension

(unit: mm)

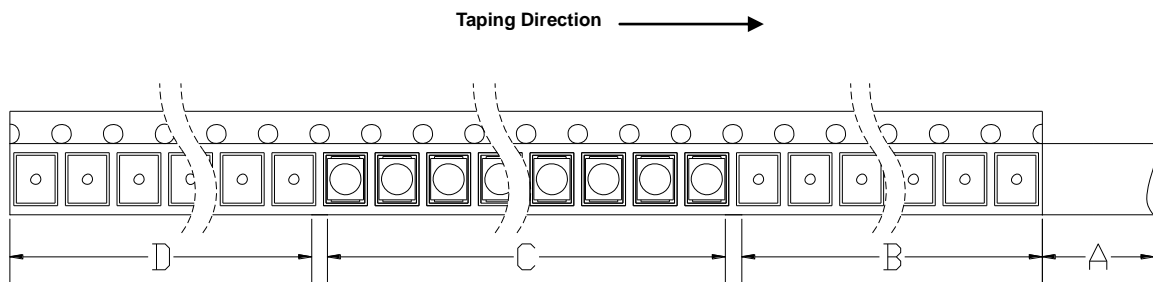
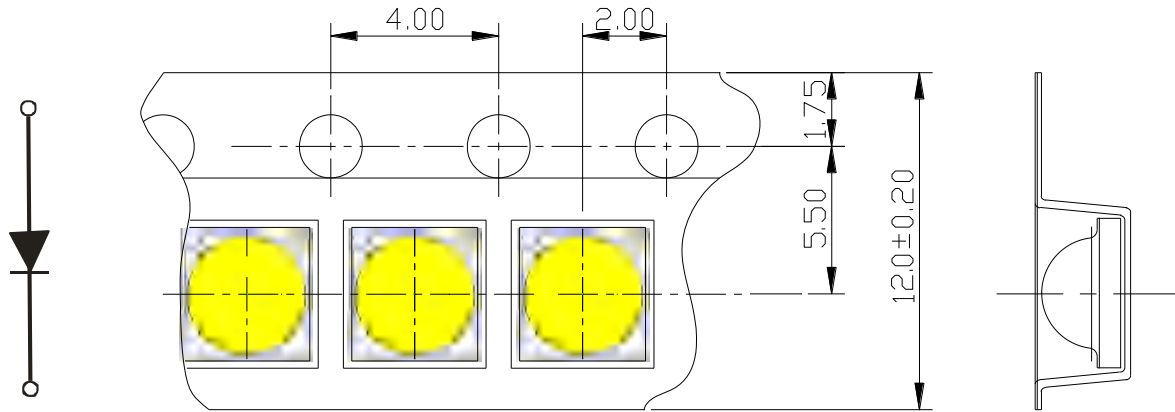

A: Top Cover Tape, 300mm; B: Leader, Empty, 200mm; C: 1000 Lamps Loaded; D: Trailer, Empty, 200mm.

b) Reel Dimension

(unit: mm)

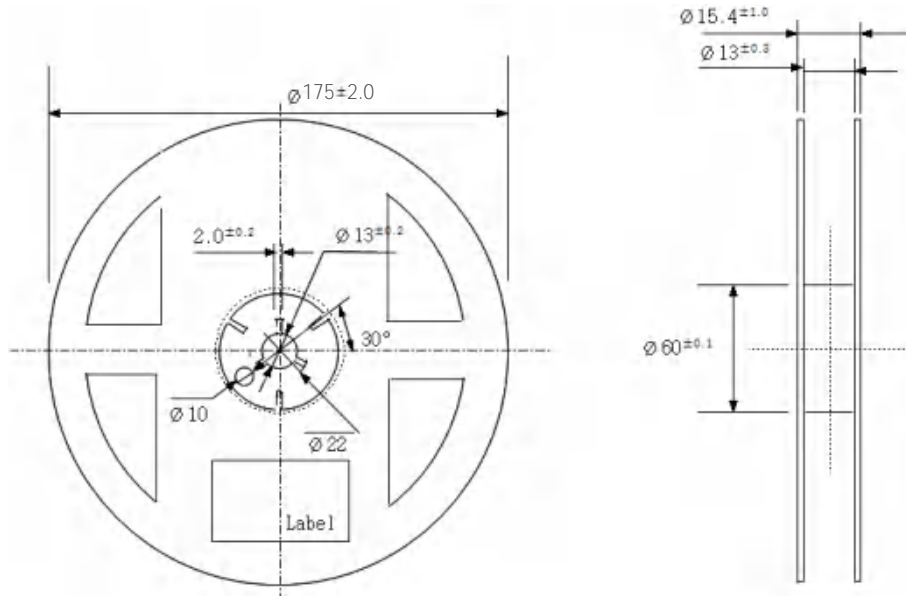

Notes:

- 1) Quantity: The quantity/reel is 1,000 pcs
- 2) Cumulative Tolerance: Cumulative tolerance / 10 pitches is ± 0.2 mm
- 3) Adhesion Strength of Cover Tape: Adhesion strength is 0.1-0.7 N when the cover tape is turned off from the carrier tape at 10° angle to the carrier tape
- 4) Packaging: P/N, Manufacturing data code no. and quantity are indicated on the aluminum packing bag

8. Label Structure

a) Label Structure



Note: Denoted bin code and product code above is only an example (see description on page 5)

b) Label Explanation

Part No.:Product Code

IF:Testing Current

VF:Forward Voltage Range

Flux:Luminous Flux Range

CCT:Color Temperature Range

Date:Packing Date

Bin Code:Rank

C/N:Internal Identification Code

Remark:Special Remark

QTY:Quantity

Lot No.:Production batch Number

9. Packing Structure

a) Packing Process (The quantity of PKG on the Reel to be Max 1,000pcs)

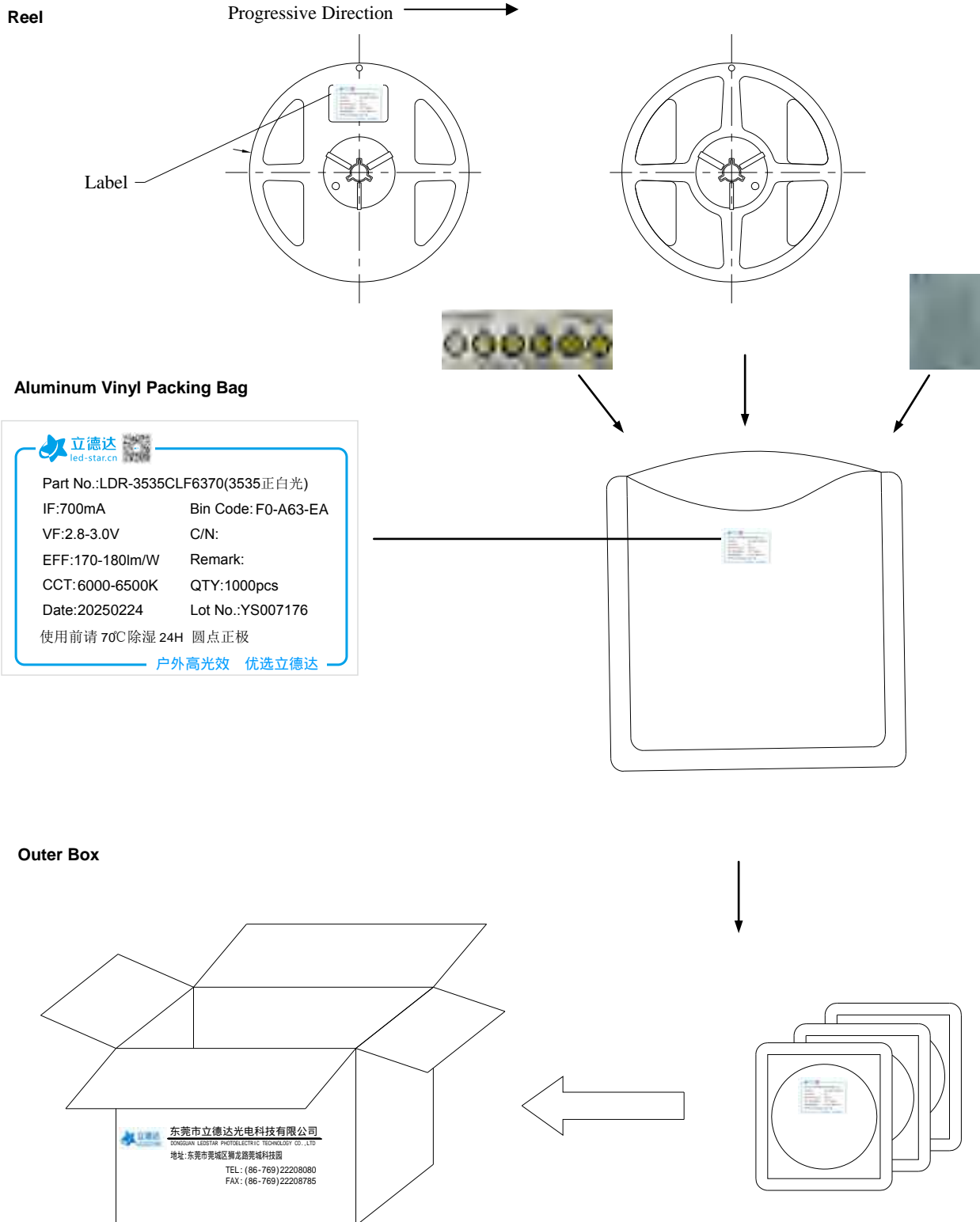

b) Aluminum Vinyl Packing Bag



c) Silica Gel & Humidity Indicator Card inside Aluminum Vinyl Bag

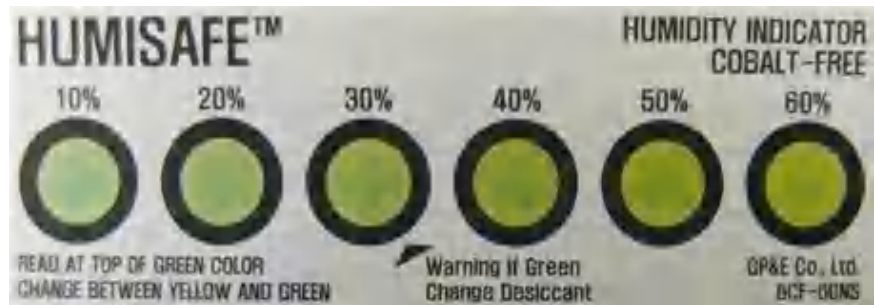

10. Precautions in Handling & Use

- 1) For over-current protection, users are recommended to apply resistors connected in series with the LEDs to mitigate sudden change of the forward current caused by shift of forward voltage.
- 2) This device should not be used in any type of fluid such as water, oil, organic solvent, etc. When cleaning is required, IPA is recommended as the cleaning agent. Some solvent-based cleaning agent may damage the silicone resins used in the device.
- 3) When the device is in operation, the forward current should be carefully determined considering the maximum ambient temperature and corresponding junction temperature.
- 4) LEDs must be stored in a clean environment. If the LEDs are to be stored for three months or more after being shipped from Ledstar, they should be packed with a nitrogen-filled container (shelf life of sealed bags is 12 months at temperature 0~40 °C, 0~90 % RH).
- 5) After storage bag is opened, device subjected to soldering, solder reflow, or other high temperature processes must be:
 - a. Mounted within 672 hours (28 days) at an assembly line with a condition of no more than 30 °C / 60 % RH^{*Note 1}, or
 - b. Mounted within 24 hours (1 day) at an assembly line with a condition of more than 30 °C / 70 % RH^{*Note 2}, or
 - c. Stored at <10 % RH.

*Note 1, 2: IPC/JEDEC J-STD-033A, Recommended Equivalent Total Floor Life Table

Package Type and Body Thickness	Moisture Sensitivity Level	Maximum Percent Relative Humidity						Temperature
		40%	50%	60%	70%	80%	90%	
Body Thickness <2.1mm	Level 2a	∞	∞	28	1	1	1	30°C
		∞	∞	∞	2	1	1	25°C
		∞	∞	∞	2	2	1	20°C

- 6) Repack unused devices with anti-moisture packing, fold to close any opening and then store in a dry place.
- 7) Devices require baking before mounting, if humidity card reading is >60 % at 23 ± 5 °C.
- 8) Devices must be baked for 10~24 hours at 70 ± 5 °C, if baking is required.
- 9) The LEDs are sensitive to the static electricity and surge current. It is recommended to use a wrist band or anti-electrostatic glove when handling the LEDs. If voltage exceeding the absolute maximum rating is applied to LEDs, it may cause damage or even destruction to LED devices. Damaged LEDs may show some unusual characteristics such as increase in leakage current, lowered turn-on voltage, or abnormal lighting of LEDs at low current.
- 10) VOCs (Volatile Organic Compounds) can be generated from adhesives, flux, hardener or organic additives used in luminaires (fixtures). Transparent LED silicone encapsulant is permeable to those chemicals and they may lead to a discoloration of encapsulant when they exposed to heat or light. This phenomenon can cause a significant loss of light emitted (output) from the luminaires. In order to prevent these problems, we recommend users to know the physical properties of materials used in luminaires and they must be carefully selected.
- 11) Risk of sulfurization (or tarnishing)
 The LED from Ledstar uses a silver-plated lead frame and its surface color may change to black (or dark colored) when it is exposed to sulfur (S), chlorine (Cl) or other halogen compound. Sulfurization of lead frame may cause intensity degradation, change of chromaticity coordinates and, in extreme cases, open circuit. It requires caution. Due to possible sulfurization of lead frame, LED should not be used and stored together with oxidizing substances made of materials such as rubber, plain paper, lead solder cream, etc.